

## **A Validation Study of the Cross-Cultural Adaptability Inventory**

Nguyen, N. T., Nolan, L., & Biderman, M. D.

Paper presented at the annual meeting of the southern Management Association. Tampa, FL, November.

### **ABSTRACT**

The factor structure of the Cross-Cultural Adaptability Inventory was examined via a confirmatory factor analytic (CFA) approach. A series of CFA models were tested and applied at the item level to both the CCAI and Goldberg's Big Five inventory. One CFA model, in which a method bias factor was estimated, fit the data significantly better than a model without such a method effect. Further, the method factor suppressed substantive relationships such that two CCAI subscales of emotional resilience and personal autonomy became significant correlates with self-reported number of international job assignments after method variance was accounted for.

Keywords:

Cross-cultural adaptability inventory; Confirmatory Factor Analysis; Big Five personality

### *Introduction*

According to an American Society for Training and Development estimate, American companies spend an average of \$109.25 billion on employee training per year (ASTD Policy Brief, 2007). Of this, global assignment training accounts for a considerable amount given the rapid expansion of US companies into Asia and Latin America in recent years. Given this substantial financial investment in training, it is important to ensure that training programs will deliver the expected results.

Selecting and training expatriate employees remain a challenge in part due to the high costs associated with international assignments - two to three times for an average employee and ten to fifteen times for higher level executives. The failure rate of expatriate employees, those who repatriate early or those who stay in their assignments, but are less productive, increase these costs considerably. Despite these high costs, expatriate assignments are expected to increase (McNary, 2000).

### *Expatriate Employee Research*

The shifts in the field of expatriate employee research are dramatic. Bhawuk (2000) tracked the applied, theoretical, and empirical integration and maturation of the field from the 1970s through the 1990s. By the mid-1990s, the field focused on the concept of “cross-cultural adaptability” to different economic, social, and political environments, which was identified as the primary reason for the high expatriate failure rate (McNary, 2000).

Thus, expatriate selection was determined to be critical, and the field became more dynamic as it moved to developing instruments that would assess cross-cultural adaptability. There are now dozens of such instruments on the market. The majority of

these instruments is highly proprietary, expensive, and requires various levels of training for administration. Though these cross-cultural instruments should predict expatriate employee success, the reliability and validity data are questionable, and there are very few empirical studies by independent researchers.

One instrument in particular has received a great deal of attention, the Cross Cultural Adaptability Inventory (CCAI), which is now a widely used assessment tool in cross-cultural training for global assignments (Davis & Finney, 2006). Kelley and Meyers (1992) developed the CCAI based on the assumption that cross cultural adaptability is an ability that is amenable to training. They first constructed the CCAI in 1987 with fifty items, 10 items each representing each of five subscales labeled emotional resilience, flexibility/openness, perceptual acuity, personal autonomy, and positive regard for others. Positive regard was eliminated during a later validation study (Kelley & Meyers, 1995).

According to the CCAI manual, emotional resilience refers to “the ability to deal with stressful feelings in a constructive way and to bounce back from them”; flexibility/openness refers to the extent to which people are “open and flexible” as well as “tolerant and non-judgmental”; perceptual acuity refers to “verbal and nonverbal behavior, to the context of communication, and to interpersonal relations”; and personal autonomy refers to one’s sense of identity without being overly reliant on environmental cues (Kelley & Meyers, 1995, p. 14).

The final CCAI instrument consists of fifty items designed to reflect four dimensions or subscales of cultural adaptability, namely emotional resilience (measured

by 18 items), flexibility/openness (measured by 15 items), perceptual acuity (measured by 10 items), and personal autonomy (measured by 7 items).

The CCAI is the first inventory measuring cross-cultural adaptation to be included in the *Mental Measurements Yearbook (MMY)* in 2001 where it classified in the subject index in the category of “personality” and claims to be “designed to provide information to an individual about his or her potential for cross-cultural effectiveness” (p. 361). However, in detailing the instrument’s content and construct validity, the *MMY* warns against the use of the CCAI for “diagnostic purposes” (p. 363). But this is exactly what is happening.

A Google search using the key words of cross-cultural adaptability inventory training returned 179,000 hits, some on which show the instrument being used in both public and private institutions for both self-development and global assignment training purposes. Despite the popularity of the CCAI in global assignment training, validation studies of the instrument are scarce. The one validation study conducted by the scale developers was based on an exploratory factor analysis (EFA). An EFA of the CCAI was also conducted in another unpublished study (Gelles, 1996). In a recent study, the first one to examine the psychometric properties of the CCAI via a series of confirmatory factor analyses (CFA), Davis and Finney (2006) found weak support for the four originally proposed CCAI factors. However, it is not possible to discern in their study whether the lack of model fit was due to the lack of unmodeled factor dimensionality or to unmodeled item covariances due to factors such as common method bias.

*Common Method Bias*

A major concern in studies with self-report methodologies is the possibility of common method bias being responsible for substantive relationships when variables representing multiple dimensions are collected from the same source (Podsakoff, MacKenzie, Lee, & Podsakoff, 2003). Specifically, the issue is that the observed covariances between variables of interest could be inflated or deflated by variance due to the method rather than to the underlying constructs or variables of interest.

The potential for the CCAI to be influenced by common method bias, although not yet empirically addressed, may have both substantive and practical ramifications. First, because the CCAI is a self-report measure, a substantive implication of examining common method bias is that the CCAI's true validity may be uncovered. Previous research has shown that common method bias can introduce contamination or noise to the observed scale scores and suppressed the substantive relationships among scale scores and a criterion measure. For example, Biderman, Nguyen, and Sebren (2008) found that the correlation between Conscientiousness and an objective measure of academic performance went from .09 ( $p > .05$ ) when the measure of Conscientiousness was contaminated by common method variance to .20 ( $p < .05$ ) after method variance was accounted for. On the other hand, Nguyen, Biderman, Cunningham, and Ghorbani (2008) found that correlations among the Big Five latent variables in CFAs of seven datasets were substantially reduced when method bias was included in the CFA models.

In another study examining the relationship between impression management and cross-cultural adaptation, both impression management and self-deceptive enhancement subscales of social desirability from the balanced inventory of desirable responding (Paulhus, 1984) were found to predict scores on the CCAI ( $r = .21$  and  $r = .29$

respectively,  $p < .05$ ) (Montagiani & Giacalone, 1998). Given the fact that common method bias may represent impression management, it may be that the CCAI items are contaminated by common method bias. Second, in terms of practical implication, common method bias is important to understand if global assignment training is expected to deliver desired results

### *The current research*

The present study addresses three important gaps in the literature. First, we wanted to replicate and extend Davis and Finney's (2006) factor analytic study of the CCAI by comparing a one-factor solution with the four-factor solution examined by Davis and Finney and then by exploring the effects of introducing a common method factor to account for across-item correlations. Given the substantial evidence of the importance of method bias in a variety of studies involving self-report questionnaires, we expect that it also plays a role in responses to the CCAI. Thus,

*Hypothesis 1:* Estimating a method effect in addition to the four *a priori* constructs will significantly improve the CFA model fit when modeled at the individual item level.

Second, we wanted to extend Davis and Finney's (2006) factor analytic study of the CCAI by providing some construct validity evidence of the scale. To this end, we included a well established and validated personality instrument, Goldberg's Big Five questionnaire available to the public on the web at <http://ori.ipip.org> to examine the extent to which the CCAI has convergent and discriminant validity.

As presented, cross-cultural adaptability by definition refers to one's readiness to interact with and/or adapt to different cultures (Kelley & Meyers, 1995). This means that

cultural adaptability is a combination of social skills and personality, the latter of which is defined as “individual characteristic patterns of thought, emotion, and behavior, together with the psychological mechanisms – hidden or not – behind those patterns” (Funder, 2001, p. 2). Thus, if one’s readiness to adjust or adapt to a different culture is partly guided by one’s natural behavioral tendencies, i.e., personality, it is reasonable to expect one’s personality to share common variance with cultural adaptability. However, to date, no research has addressed this question empirically.

Due to the absence of research guiding our hypothesized relationships between personality and cross-cultural adaptation, in this study, we wanted to explore the above linkages based on the overlap in *construct space* from the definitions of CCAI subscales and Big Five traits. Where possible, we provided empirical evidence to support our hypotheses concerning the expected relationships.

The Big Five personality is the most well-known taxonomy of personality, consisting of five dimensions namely Extraversion, Agreeableness, Conscientiousness, Neuroticism (often measured as Emotional Stability), and Openness to Experiences (sometimes called Intellect) (Saucier & Goldberg, 2003). Extraversion is defined as the extent to which one is outgoing and sociable. Agreeableness refers to one’s tendency to be good-natured, warm, and cooperative. Conscientiousness is defined as the extent to which an individual is hardworking, organized, reliable, and strong-willed. Emotional stability refers to the extent to which an individual is calm, collected, and good-tempered. Openness to experience is defined as the degree to which one is both aesthetically and emotionally aware of feelings and ideas (Goldberg, 1993).

Considering the overlap in definitions of both the CCAI and the Big Five, we expect that the overall CCAI score to be positively related to two measures of the Big Five personality, i.e., conscientiousness and emotional stability because these two personality traits have been found to be valid predictors of overall job performance across a wide variety of jobs including expatriate job performance (Barrick, Mount, & Judge, 2001). In addition, we also expect the overall CCAI score to positively correlate with openness to experience because openness to experience has been shown to be a valid predictor of training performance (e.g., Dean, Conte, & Blankenhorn, 2006; Gully, Payne, Koles, & Whiteman, 2002). Since the CCAI's popular in global assignment training, it is expected that its scale score to correlate with openness to experience. Thus,

*Hypothesis 2:* CCAI scores will be positively related to conscientiousness, emotional stability, and openness to experience.

In terms of the CCAI subscale correlates with the Big Five, we expect that the flexibility/openness factor of the CCAI to be significantly and positively correlated with two Big Five personality factors of agreeableness and openness to experience/ intellect due to an overlap in definition of the factors. We also expect the emotional resilience factor of the CCAI to be positively related to the Big Five factor of emotional stability for the same overlapping in definition. Finally, we expect perceptual acuity to positively correlate with the Big Five factor of extroversion and personal autonomy to positively correlate with the Big Five factor of conscientiousness. Since there is almost no research guidance in this area to warrant hypotheses, we decided to treat the above expected relationships as exploratory.

Finally, to examine the criterion-related validity of the CCAI, we included one dependent variable of self-reported international trips taken as job assignment. Since higher CCAI scores indicate better cultural adaptability, it is reasonable to expect that a high degree of cultural adaptability will lead to repeated job assignments. In fact, one study found a positive correlation between prior international experience and better subsequent adjustment to international assignment (Huang, Chi, & Lawler, 2005). Thus, *Hypothesis 3*: CCAI scores will be positively related to number of international job assignments.

## **Method**

### *Participants*

Two hundred and one undergraduate and MBA students from a south central university participated in the study in exchange for partial course credit. No student names were collected. Due to missing data, the final sample was 175. Of these 175 students, 84 (48%) were male with an average age of 24.5 (SD = 6.35; minimum = 19; maximum = 53). The sample was predominantly White (134 or 76.6%) with 11.4% Black, 6.3% Asian, and 5.7% Hispanics.

### *Procedure*

Data were collected during class time to maximize response rate. All participants were given the CCAI followed by Goldberg's IPIP questionnaire. The original administration instructions for both scales were used. For the CCAI, scale anchors ranged from 1 "definitely true" to 6 "definitely not true". For the IPIP, scale anchors ranged from 1 "very inaccurate" to 5 "very accurate". Participants were asked to respond honestly to all measures.

## *Measures*

### *Independent variables*

*Emotional resilience.* 18 items from the CCAI represent this dimension. Sample items include “I have ways to deal with the stresses of new situations”; “I feel confident in my ability to cope with life, no matter where I am”. Cronbach alpha for this measure was .81.

*Flexibility/Openness.* This variable was measured with 15 items from the CCAI. Sample items include “I like being with all kinds of people”; “When I meet people who are different from me, I am interested in learning more about them”. Cronbach alpha was .67.

*Perceptual Acuity.* This dimension was measured using 10 items from the CCAI. Sample items include “I try to understand people’s thoughts and feelings when I talk to them”. “I can perceive how people are feeling, even if they are different from me”. Cronbach alpha was .81 for this variable.

*Personal Autonomy.* The remaining 7 items of the CCAI were used to measure this dimension. Sample items include “I believe that all people, of whatever race, are equally valuable”, “My personal value system is based on my own beliefs, not on conforming to other people’s standards. Cronbach alpha was .63 for this variable. The reliability estimates for all CCAI sub-scales were comparable to those reported in Davis and Finney (2006).

### *Personality.*

The International Personality Item Pool (IPIP), developed by Lewis Goldberg, is a popular personality instrument available at no-cost to the public. The 50-item version of the IPIP scales has been recently validated and shown to have good reliability and validity compared to other established five factor measures of personality such as the

NEO-FFI (Lim & Ployhart, 2006). Five factors of personality that the IPIP is purported to measure include extraversion, agreeableness, conscientiousness, emotional stability, and openness to experience with each factor measured by ten IPIP items. The reliability estimates for the five above mentioned factors were .89, .83, .77, .85, and .77 respectively. Thus, compared to the CCAI, the IPIP scales were more internally consistent.

#### *Dependent variable*

*International job assignments taken.* One item was used to ask participants to report the number of international trips they had taken in the past as part of their job assignment. Since it was a one-item measure, no reliability estimates were available for this variable. This variable was highly skewed, thus, transformation using logarithm to base 10 was taken to partially normalize the variable.

#### *Analyses*

All CFA models were estimated using Mplus V5.0 (Muthén & Muthén, 1998-2007). We began the investigation of the factor structure of the CCAI items by creating two CFA models of the 50 CCAI items. Model 1 contained one latent variable representing an overall cross-cultural adaptability factor indicated by all 50 CCAI items. Thus, Model 1 was a standard CFA model of the CCAI items with individual items as indicators of the latent variable CCAI. Model 2 contained four latent variables representing four originally proposed factors or subscales of the CCAI, i.e., ER – emotional resilience; FO – Flexibility/Openness; PAC – personal acuity; and PAU – personal autonomy. Thus, Model 2 was a standard CFA model of the CCAI items with 18 items loading on ER, 15 items loading on FO, 10 items loading on PAC, and 7 items

loading on PAU factors respectively. Figure 1 shows this Model. Model 2 is a generalization of Model 1 and thus the fit of the two models can be tested using chi-square difference test. If Model 2 shows a better fit than Model 1, there is evidence supporting the four proposed factors by the scale authors: C. Kelley and J. Meyers.

To explore the extent to which a method factor might influence responses to the CCAI items, it was our intent to create a third model adding a method factor to Model 2. Unfortunately, as described below, it was not possible to obtain convergence of this method factor model when applied to the CCAI items only. Thus, we decided to incorporate the investigation of the method factor using the models designed to test hypothesis 2. To this end, three other CFA models were tested. All of these were models of an augmented dataset including both the CCAI items and the IPIP Big Five items. Model 1A included one overall CCAI latent variable and five latent variables representing the Big Five factors of extraversion, agreeableness, conscientiousness, emotional stability, and openness/intellect respectively. All 50 CCAI items were allowed to load on the overall CCAI factor whereas ten items each were allowed to load on the appropriate Big Five latent variable. Correlations among the latent variables were estimated. Thus, Model 1A replicated Model 1 but was a standard CFA model of both the CCAI and the IPIP 50-items. .

Model 2A generalized Model 1A by requiring the CCAI items to load on four factors, replicating Model 2 with the augmented dataset. This model contained nine latent variables, i.e., four CCAI factors and five Big Five factors. Correlations between all factors were estimated.

Model 3A was a generalization of Model 2A in which a tenth latent variable, labeled M to indicate method bias was included. All 100 items were required to load on M (See Figure 2). For purposes of model identification M was constrained so that it was orthogonal to all of the Big Five and CCAI factors (Williams, Ford, & Nguyen, 2002).

-----  
Insert Figures 1 & 2 about here  
-----

We used various goodness-of-fit statistics for model evaluation. We reported the Chi-square statistic, Comparative Fit Index (CFI), the Root Mean Square Error of Approximation (RMSEA); and the Standardized Root Mean Square Residual (SRMR). As noted in prior research, whereas RMSEA has been found to be most sensitive to misspecified factor loadings (a measurement model misspecification); SRMR has been found to be most sensitive to misspecified factor covariances (a structural model misspecification) (Hu & Bentler, 1999). Later studies replicating Hu and Bentler's seminal work confirmed that SRMR and RMSEA values were found to perform better than other fit indexes at both retaining a correctly specified (i.e., true) model and rejecting a misspecified model (Sivo, Fan, Witte, & Willse, 2006). Thus, both values are reported in this study. Whereas models with CFI values close to .95 are reported as having a good fit to the data, RMSEA values less than .06 and SRMR values less than .08 are considered acceptable fit (Hu & Bentler, 1999).

## **Results**

Table 1 presents the above-mentioned fit statistics of Models 1 and 2. As shown in the Table, both Model 1 and Model 2 fit the data poorly based on Comparative Fit Index (CFI) and Tucker-Lewis Fit Index (TLI). For Model 1 in which CCAI was

assumed to be a unidimensional factor, CFI and TLI were .579 and .561 respectively. However, RMSEA and SRMR were closer to acceptable standards. They were .074 and .083 respectively for Model 1. Model 2 in which CCAI was assumed to include four intercorrelated subscales or factors as originally proposed by Kelley and Meyers (1995) showed a significant improvement in fit. CFI and TLI were .602 and .583 respectively. RMSEA and SRMR were .072 and .084 respectively. The chi-square reduction from Model 1 to Model 2 was statistically significant, indicating that Model 2 fit the data better ( $\Delta\chi^2_{(6)} = 67.42, p < .01$ ). Although the CFI and TLI were much lower than traditional “acceptability” cutoffs in Model 2, the SRMR indicates that a four factor model was a close fit to the data based on Hu and Bentler’s (1999) recommended cutoff of .08. Thus, we retained Model 2 and proceeded to models of the augmented data for the following reasons. First, we note that poor fit is generally characteristic of models in which items serve as indicators. Second, the CFI, TLI, and RMSEA are very sensitive to complex model misspecification (Hu & Bentler, 1999), thus their values lower than traditional cutoffs may signal the existence of other unmodeled item covariances such as those shared with a common method factor. Third and lastly, although fit indices such as CFI, TLI, and RMSEA can be significantly improved by grouping individual items into parcels (e.g., Lim & Ployhart, 2006; McMahan & Harvey, 2007), we decided against this practice because doing so would obscure the contribution of individual items into the shared variances with the common method factor.

The application of Models 1 and 2 served two purposes. First, they provided evidence that the items that the CCAI items are not merely indicators of one dimension. Second, they confirmed the relatively poor fit of the four-factor CFA originally

investigated by Davis and Finney (2006), although the extent to which the fit appears poor because of absence of a method factor from the model remains to be seen. Although our original intent had been to move directly to a test of Hypothesis 1 for the CCAI items only by adding a method factor to Model 2, we were unable to obtain convergence of the method factor model. We suspect that the failure to converge was due to high correlations between the CCAI factors. Since high interfactor correlations will lead to high interitem correlations across dimensions - the same interitem correlations that a method factor would account for - it appears that the covariances among the CCAI items due to M, if any, were not separable from the covariances among them due to the high interfactor correlations

Since method bias is presumed to affect responses to all items, regardless of the scale to which they belong, we decided it was appropriate to investigate the effects of method bias with the augmented data in which both CCAI and IPIP items were modeled. Since the Big Five factors have been found to be far less highly correlated than the CCAI factors (e.g., Lim & Ployhart, 2006; Davis & Finney, 2006) we felt that covariances between Big Five items due to M would be easily separable from covariances due to correlations among the factors and thus would permit estimation of influences due to both M and to interfactor correlations. Thus we performed the second set of analyses applying models to the augmented dataset consisting of both the CCAI items and the IPIP items. To insure that addition of the IPIP items did not alter our conclusions regarding the factor structure of the CCAI items, we first replicated the comparison of a one-factor CCAI model with a four-factor CCAI model using the augmented dataset., comparing the fit of Models 1A and 2A, models corresponding to Models 1 and 2 but applied to the

augmented dataset. Table 1 presents the results of this comparison. As can be seen by inspection of Table 1, Model 2A fits significantly better than Model 1A, replicating the comparison of Models 1 and 2 suggesting that a four factor structure of the CCAI items fits better than a one-factor structure.

On the expectation that adding a method factor to the CFA of the augmented dataset would yield convergence when its addition to the CCAI items did not, Model 3A was applied. In this model, the CCAI items and the IPIP items were all assumed to be influenced by a single method factor, labeled M in Figure 2. The expectation was correct in that the model with a method bias factor converged.

Hypothesis 1 was evaluated using the chi-square difference test comparing Model 3A to Model 2A. The chi-square reduction from Model 2A to Model 3 was statistically significant, indicating that Model 3A in which a common method factor was estimated fit the data better than Model 2A ( $\Delta\chi^2_{(100)} = 516.40, p < .01$ ). Both the CFI and TLI were higher in Model 3 compared to Model 2A. Thus, Hypothesis 1 was supported.

-----  
 Insert Tables 1, 2 & 3 about here  
 -----

The creation of an augmented dataset, while an expedience to solve the convergence problem of the method bias model, also allowed tests of expectations concerning relationships between CCAI dimensions and the Big Five dimensions – those of Hypothesis 2. Hypothesis 2 states that CCAI scores will be positively related to conscientiousness, emotional stability, and openness to experience, latent correlations between the CCAI scores, its subscales and the Big Five factors from the IPIP data were computed. They are shown in Table 2. As shown in the Table, CCAI scale scores were

positively correlated with all of the Big Five traits in Model 1A. Specifically, the correlations with conscientiousness and emotional stability were .278 and .447 respectively. CCAI scores were also positively correlated with openness to experience ( $r = .483, p < .001$ ). This pattern of finding provides preliminary support for the convergent validity of the CCAI as a whole scale. Thus, Hypothesis 2 was supported.

Hypothesis 3 states that CCAI scores will be positively related to number of international job assignments. To test this hypothesis, correlations between CCAI and Big Five dimensions as well as the logarithm of number of trips taken were estimated. These correlations were obtained by adding the logarithmic number of international job assignment (LGTRIPS) variable to Models 1A, 2A and 3A and estimating correlations between it and the latent variables in the model. Recall that Model 1A was a six latent variable model with one CCAI and five Big Five variables, Model 2A was a nine-latent variable model without a method factor. Model 3 was a 10-latent variable model with a method factor.

Table 3 presents the correlations of LGTRIPS with the latent variables from each model. As can be seen from inspection of the table, LGTRIPS was not correlated with the CCAI latent variable ( $r = .081, p = .296$ ). LGTRIPS was also not related with any latent CCAI subscales from Model 2A. On the other hand, it was correlated significantly with both emotional resilience (ER) and personal autonomy (PAU) from Model 3 ( $r_s = .202$  and  $.289$  respectively). None of the Big Five dimensions were significantly related to LGTRIPS in Models 1A, 2A, and 3.

We attribute the difference between the correlations of LGTRIPS to CCAI factors in Models 1A and 2A vs. those of Model 3A to the noisy presence of method variance in

estimates of the latent variables of Models 1A and 2A. In Model 3A, this method variance was removed from the estimates of the CCAI and Big Five latent variables, revealing the relationships between ER, PAU, and LGTRIPS. However, the two remaining CCAI subscales of flexibility/openness (FO) and personal acuity (PAC) were not related to number of international assignments. Thus, hypothesis 3 was partially supported.

We point out the decreases in correlations among the CCAI subscales and among the Big five latent variables when moving from Model 2A to Model 3A (See Table 2 and 3). Those changes are substantial, suggesting that the estimation of method bias makes a big difference on the estimated factor structure of the CCAI as well as personality questionnaires. This is consistent with previous method bias research (Nguyen et al, 2008).

In terms of the CCAI subscale correlates with the Big Five, as expected, the flexibility/openness factor of the CCAI was positively related to Openness ( $r = .215, p < .05$ ) in Model 3A. However, the correlation between flexibility/openness and agreeableness, albeit in the right direction, was not significant in Model 3A ( $r = .117, n.s.$ ).

As expected, the emotional resilience factor of the CCAI was positively related to the Big Five factor of emotional stability in Model 3A ( $r = .351, p < .01$ ). Next, contrary to our expectation, perceptual acuity was not related to extroversion in Model 3A ( $r = -.195, p = .082$ ). Finally, as expected, personal autonomy was positively correlated with conscientiousness in Model 3A ( $r = .284, p < .01$ ). Taken together, the above findings provide some support to the convergent validity of the CCAI and its subscales.

Also shown in Table 3 is evidence of the poor discriminant validity of the CCAI subscales. The four CCAI subscales were highly correlated with one another even after controlling for method bias. Specifically, when method bias was not estimated (Model 2A), the range of intercorrelations among the four CCAI subscales was .765 to .930 with a mean of .846. After a common method factor was introduced and estimated, these correlations decreased to ranging from .546 to .883 with a mean of .730 (Model 3A). These high correlations among the CCAI subscales demonstrate the lack of differentiation among the subscales and thus poor discriminant validity of the individual CCAI subscales.

*Factor determinacies of the CCAI subscales*

We report the factor determinacies to represent latent variable reliabilities as opposed to scale reliabilities (Raykov, 2001) for the following reasons. First, when each item indicates only one latent variable, then it makes sense to compute scale reliabilities by summing the loadings of the indicators using the Raykov's (2001) formula. In this case, however, each item indicates two latent variables - a dimension latent variable and the method factor. Since it was not possible to compute the substantive variable scale in the normal way by adding items because of the contamination of the common method factor, scale score estimates of latent variables uncontaminated by M only exist as factor scores from the CFA estimates of Model 3A. Thus, factor score determinacies are appropriate to indicate the reliabilities of those scales. Factor determinacies of CCAI subscales for Model 3 were .926, .875, .939, and .883 for ER, PO, PAC, and PAU respectively. These values represent estimates of the correlations between estimated and true factor scores (Muthén & Muthén, 1998-2007).

## Discussion

In this study, we found that the CCAI, if analyzed appropriately such that common method bias is taken into account, demonstrates some construct validity. Specifically, controlling for common method bias, two CCAI subscales of emotional resilience and personal autonomy were found to predict the number of international assignments. This may explain why lack of validity was reported in some previous studies. For example, Jensma (1996), using correlation analysis, failed to find support for the predictive validity of the CCAI in cultural adaptation among a sample of 37 missionaries. It is possible common method bias might have suppressed the true substantive relationship of the CCAI and its criterion.

In this study, we provided another example in which method bias had a profound effect, suppressing substantive conclusions; in this case it suppressed the correlations of ER and PAU with LGTRIPS in Model 2A. Those correlations were revealed in Model 3A. Our findings were consistent with previous research (e.g., Biderman et al, 2008). Moreover, we provided evidence that failing to account for method bias results in upwardly biased estimates of correlations between latent variables – the Model 2A latent variables were much more positively correlated than the Model 3A latent variables, consistent with Nguyen et al's (2008) findings.

It is important to note that two CCAI subscales, i.e., personal acuity (PAC) and flexibility/openness (FO) were not significantly related to international job assignments. This finding is tantalizing because openness to experience as a Big Five personality trait was found to be positively associated to both prior international experience and cultural adjustment (Huang et al., 2005). It is our conjecture that although the correlation between

FO and openness to experience in this study was positive and significant ( $r = .215$  in Model 3A), it may be the unique variance in openness unshared with FO that is related to prior international experience and cultural adjustment. Personal acuity, on the other hand, was not significantly related to openness to experience in Model 3A (see Table 2). By definition, personal acuity (PAC) refers to one's ability to be "attentive to verbal and non-verbal behavior" as well as "sensitive to the feelings of others and to the effect they have on others" (Kelley & Meyers, 1995). As the definition reveals, this dimension contains aspects of both extraversion and openness to experience - a Big Five personality trait. Whereas extraversion was found to be positively related to both prior international experience and subsequent cultural adjustment (Huang et al., 2005), it is our conjecture that the shared variance in PAC with extraversion might be too small to register an association with self-reported number of international assignments.

Finally, we also replicated Davis and Finney's (2006) result that the CCAI dimensions are quite highly correlated, with little discriminant validity. This suggests a refinement of the instrument might be needed.

#### *Contributions to research and practice*

In this study, we added to the body of method bias research yet another example showing how common method variance can serve as a suppressant of substantive relationship in relating cultural adaptation to its outcomes. This has substantial implications for research and practice. In terms of research implications, this study should be replicated in larger samples and with expatriates and their spouses. Due to the low discriminant validity of the CCAI subscales, the items may need to be revised. Special attention should be paid to items measuring personal acuity (PAC) and

flexibility/openness (FO) due to their lack of significance in predicting number of international job assignments.

In terms of practical implications, given the widespread use of the CCAI in global assignment training, this study was the first to show that the CCAI, if analyzed properly, may be a valid instrument for selection and training purposes. The fact that none of the Big Five personality dimensions were significantly related to number of international job assignments spoke a great deal to the unique explanatory power of the CCAI. The methodology employed here could be built into the test scoring system to derive a method factor score for individual test takers. A by-product of the methodology would be estimates of scores on CCAI dimensions uncontaminated by the common method factor, thus, enhancing the validity and utility of the training program for global assignment.

#### *Possible Reasons for Lack of Fit*

In this study, we demonstrated that model fit for the CCAI could be improved substantially with the addition of a common method bias factor. Even with this improvement, however, the fit was only considered acceptable based on SRMR and RMSEA values. The CFI and TLI still have room for improvement based on conventional cutoff of .95 recommended in previous studies (e.g., Hu & Bentler, 1999). We offer two potential reasons for this continued lack of fit indicated by CFI and TLI. First, an examination of the factor loadings revealed that some items on both FO and PAC scales had non-significant loadings. We ran a separate CFA in which items with non-significant loadings on the factor they were supposed to represent were removed and found an improvement in model fit. Second, some items in those two subscales are

worded in a double-barreled fashion. For example, in a FO item “When I meet people who are different from me, I expect to like them”, there are two phrases that may or may not be responded consistently and/or independently from each other. One may respond negatively to the first phrase (I don’t usually meet people who are different from me) but positively to the second phrase (but I like those who I happen to meet). The complexity of item wording may have caused the lack of clear loading pattern on the factor the items are supposed to represent. In a recent study that quantitatively reviewed the literature of item generation in scale development, poor item wording was found to be a threat to the construct validity of the scale (Ford & Scandura, 2007). This is certainly an area for future CCAI research.

#### *Limitations of the study*

Several limitations of the study should be noted. First, the student sample limits the generalizability of the finding to an expatriate population. However, given the fact that more than half of the sample reported having global assignment experience, this limitation could be assumed as being negligible. Second, the use of the same sample in modeling both the measurement and then validating the confirmed model in a structural model may have capitalized the findings here on chance. Future research should replicate this study in an expatriate sample to have more conclusive findings. Third, the use of self-reported number of international job assignments might not be a perfect outcome in global assignment training. One may desire repeated international assignments but may not perform well in such assignments. Thus, other outcomes such as expatriate performance and/or adjustment should be examined to have a comprehensive validation study of the CCAI.

## CONCLUSIONS

Despite decades of studies investigating cross-cultural adaptation in expatriate selection and training, little research exists to model the construct using confirmatory factor analytical approach. This study was one of the first to validate the CCAI using structural equation models. It represents a means of isolating the effects of each cultural adaptability dimension on subsequent expatriate adjustment and performance, which is critical in better understanding cross-cultural adaptability training and selection for global assignment. It is hoped that the results of this study are a significant step toward that direction.

## REFERENCES

- ASTD Policy Brief (2007). <http://www.astd.org/NR/rdonlyres/8C6FDB15-3861-4C27-86DF-7F35917E4A57/12977/January2007APB.pdf> Retrieved on March 17th 2008.
- Bhawuk, D. P. S. (2000). Cross-cultural training: A Review. *Applied Psychology: An International Review*, 49 (1), 162-192.
- Barrick, M.R., Mount, M.K., & Judge, T.A. 2001. The FFM personality dimensions and job performance: Meta-analysis of meta-analyses. *International Journal of Selection and Assessment*, 9: 9-30.
- Biderman, M. D., Nguyen, N. T., & Sebren, J. 2008. Time on task mediates the conscientiousness-performance relationship. *Personality and Individual Differences*, 44, 887-897.
- Davis, S. L., & Finney, S. J. 2006. A factor analytic study of the cross-cultural adaptability inventory. *Educational and Psychological Measurement*, 66, 318-330.
- Dean, M. A.; Conte, J. M.; & Blankenhorn, T. R. 2006. Examination of the predictive validity of Big Five personality dimensions across training performance criteria. *Personality and Individual Differences*, 41, 1229-1239.
- Ford, L.R., & Scandura, T. A. 2007. *Item generation: A review of commonly-used measures and recommendations for future practice*. Paper presented at the 2007 Annual Meeting of the Southern Management Association: Nashville, TN
- Funder, D.C. 2001. *The personality puzzle* (2<sup>nd</sup> ed.). New York: Norton.
- Gelles, R. S. 1996. *Expatriate adjustment and performance, and spouse adjustment*. Dissertation Abstracts International: Section B: The Sciences and Engineering, 57(2-B), pp. 1483.
- Goldberg, L.R. 1993. The structure of phenotypic personality traits. *American Psychologist*, 48(1): 26-34.
- Gully, S. M., Payne, S. C.; & Koles, & Whiteman, K. L. 2002. The impact of error training and individual differences on training outcomes: An attribute-treatment interaction perspective. *Journal of Applied Psychology*, 87, 143-155.
- Huang, T.J., Chi, S.C., & Lawler, J.J. 2005. The relationship between expatriates' personality traits and their adjustment to international assignments. *International Journal of Human Resource Management*, 16(9): 1656-1670.

- Hu, L. & Bentler, P. M. 1999. Cutoff criteria for fit indexes in covariance structure analysis: Conventional criteria versus new alternatives. *Structural Equation Modeling*, 6: 1-55.
- Jensma, J. L. 1996. *A pilot study examining the predictive validity of the Cross-Cultural Adaptability Inventory among first-term missionaries*. Dissertation Abstracts International: Section B: The Sciences and Engineering, Vol 56(10-B), Apr 1996. pp. 5835.
- Kelley, C., & Meyers, J. 1995. *The cross-cultural adaptability inventory*. Minneapolis, MN: National Computer System.
- Lim, B-C., & Ployhart, R. E. 2006. Assessing the Convergent and Discriminant Validity of Goldberg's International Personality Item Pool: A Multitrait-Multimethod Examination. *Organizational Research Methods*, 9, 29-54.
- McMahon, J.M.; & Harvey, R.J. 2007. The Psychometric properties of the Reidenbach-Robin Multidimensional Ethics scale. *Journal of Business Ethics*, 72: 27-39.
- McNary, L. D. (2000). Enhancing workgroup socialization for expatriates: A profile instrument of psychological attributes for cross-cultural adaptation. *Journal of Business and Management*, 7 (2), 71-82.
- Montagliani, A., & Giacalone, R. A. 1998. Impression management and cross-cultural adaptation. *Journal of Social Psychology*, 138, 598-608.
- Muthén, L.K., & Muthén, B.O. 1998-2007. *Mplus User's Guide. Fourth Edition*. Los Angeles, CA: Muthén & Muthén.
- Nguyen, N.T., Biderman, M.D., Cunningham, C.J., & Ghobarni, N. 2008. *A Multi-Sample Re-examination of the Factor Structure of Goldberg's IPIP 50-item Big Five Questionnaire*. Paper presented at the Academy of Management Meeting, Anaheim, CA.
- Paulhus, D. L. 1984. Two-component models of social desirable responding. *Journal of Personality and Social Psychology*, 46, 598-609.
- Plake, B. S., & Impara, J. C. (Eds.). 2001. *The fourteenth mental measurements yearbook*. Lincoln, NE: The University of Nebraska.
- Podsakoff, P. M., MacKenzie, S. B., Lee, J., & Podsakoff, N.P. 2003. Common method biases in behavioral research: A critical review of the literature and recommended remedies. *Journal of Applied Psychology*, 88, 879-903.

- Raykov, T. (2001). Estimation of congeneric scale reliability using covariance structure analysis with nonlinear constraints. *British Journal of Mathematical and Statistical Psychology*, 54, 315-353.
- Saucier, G., & Goldber, L.R. 2003. The Structure of Personality attributes. In M.R. Barrick and A.M. Ryan (Eds.). *Personality and Work* (1<sup>st</sup> Ed.). Jossey-Bass: San Francisco, CA.
- Sivo, S. A., Fan, X., Witta, E. L., & Willse, J. T. 2006. The search for “optional” cutoff properties: Fit index criteria in structural equation modeling. *Journal of Experimental Education*, 74: 267-288.
- Williams, L. J., Ford, L. R., & Nguyen, N.T. 2002. Basic and Advanced Measurement Models for Confirmatory Factor Analysis. In S. Rogelberg (Ed.). *Handbook of Research Methods in Industrial and Organizational Psychology* (pp.366-389). Oxford: Blackwell.

Table 1. Fit statistics of alternative CFA models

Model	df	$\chi^2$	$\Delta df$	CFI	TLI	RMSEA	SRMR
1	1175	2305.101		.579	.561	.074	.083
2	1169	2237.681	6	.602	.583	.072	.084
1A	4835	9025.728		.482	.470	.070	.094
2A	4814	8900.866	21	.495	.481	.069	.093
3A	4714	8384.826	100	.547	.524	.067	.078

Table 2. CCAI Factor and Big Five Correlations of Alternative CFA Models

Factor	ER	FO	PAC	PAU	E	A	C	S	O
Model 1A									
CCAI					.433**	.421**	.278**	.447**	.483**
E						.223*	.175	.314**	.466**
A							.412**	.033	.307**
C								.010	.200*
S									.249**
O									
Model 2A									
1. ER									
2. FO	.786**								
3. PAC	.858**	.929**							
4. PAU	.930**	.765**	.810**						
5. E	.433**	.426**	.345**	.413**					
6. A	.228**	.529**	.548**	.397**	.224*				
7. C	.242**	.182	.330**	.392**	.177	.416**			
8. S	.514**	.416**	.318**	.345**	.314**	.034	.008		
9. O	.460**	.431**	.434**	.535**	.466**	.306**	.214*	.249**	
Model 3A									
1. ER									
2. FO	.699**								
3. PAC	.827**	.883**							
4. PAU	.831**	.546**	.594**						
5. E	.088	.015	-.195	.070					
6. A	-.204*	.117	.084	.030	-.247**				
7. C	.062	-.012	.120	.284**	-.009	.308**			
8. S	.351**	.099	.007	-.001	.042	-.38**	-.175		
9. O	.258**	.215*	.199	.387**	.271**	.056	.072	.024	

Note: ER = Emotional Resilience; FO = Flexibility/Openness; PAC = Perceptual Acuity; PAU = Personal Autonomy; E = Extroversion; A = Agreeableness; C = Conscientiousness; S = Emotional Stability; O = Openness to experience.

\*: significant at  $p < .05$

\*\* : significant at  $p < .01$ .

Table 3. Structural Models of CCAI Predicting International Assignment

	ER	FO	PAC	PAU	Log(trip)
Model 1A					
CCAI					.081
E					.106
A					-.020
C					.006
S					.020
O					.077
Model 2A					
ER		.788	.861	.926	.149
FO			.939	.761	.026
PAC				.814	-.019
PAU					.099
E					.106
A					-.019
C					.005
S					.021
O					.077
Model 3A					
ER		.705	.837	.827	.202*
FO			.914	.541	.076
PAC				.610	.019
PAU					.189*
E					.147
A					-.017
C					.016
S					.043
O					100

Note: \* = Significant at  $p < .05$

Figure 1. Model 2 with individual CCAI items as indicators of four latent variables: ER=Emotional Resilience; FO=Flexibility/Openness; PAC=Perceptual Acuity; and FAU=Personal Autonomy. To simplify the figure, residual latent variables are not shown.

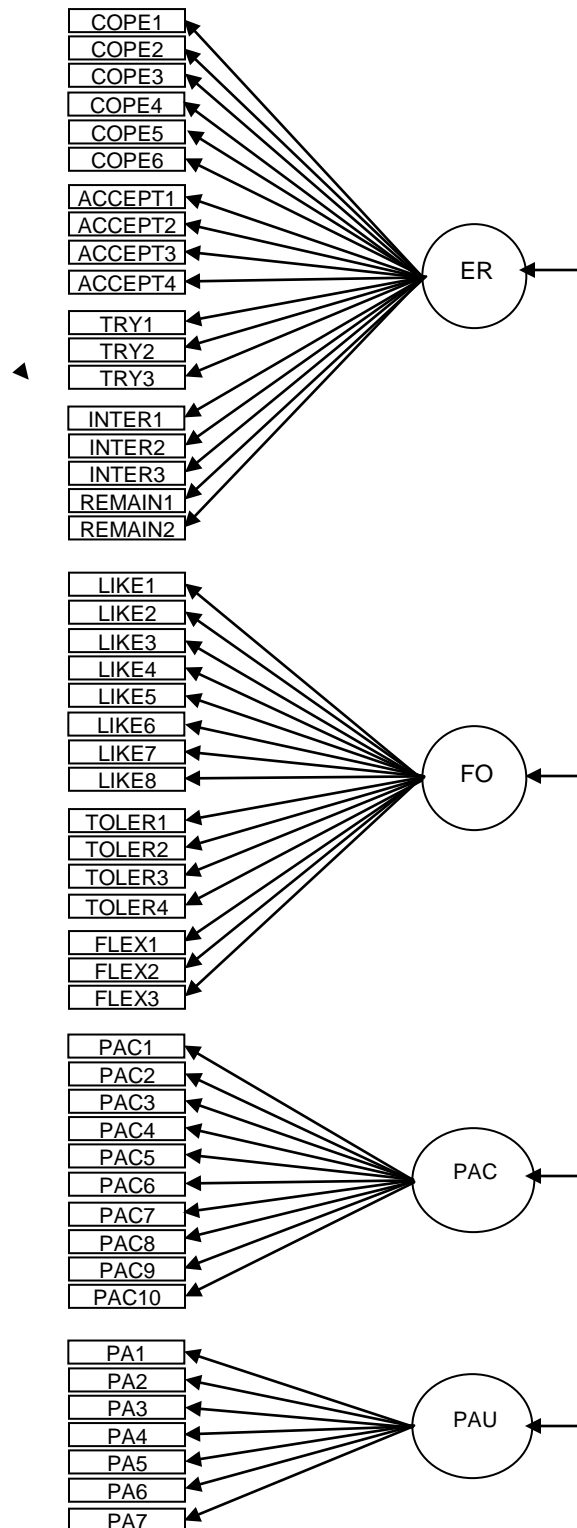

Figure 2. Measurement Model 3. Each rectangle represents a collection of items. Fan shapes between latent variables and rectangles represent the fact that individual items, not scale scores, were indicators of all latent variables. Latent variables are ER=Emotional Resilience; FO=Flexibility/Openness; PAC=Perceptual Acuity; PAU=Personal Autonomy; E=Extraversion; A=Agreeableness; C=Conscientiousness; S=Stability; and O=Openness/Intellect.

