

**DATA TABLE FOR DIODE POWER SUPPLY EXPERIMENT
PHYSICS 281 SUMMER AM I 2002**

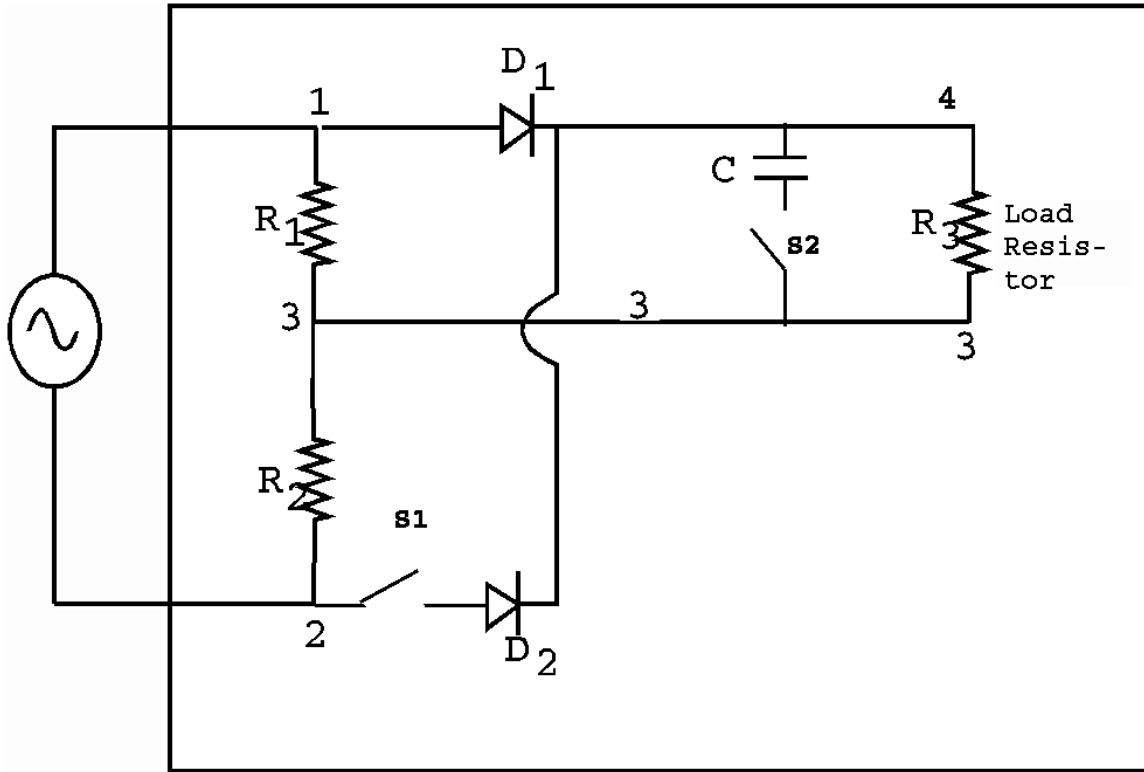

CIRCUIT DIAGRAM

The AC/DC/Ground switch on the oscilloscope should be should be set to the DC position for the following measurements

Location of Probe	Location of Ground	Component s in circuit	Vpp	Vmax Amplitude	V _{rms}	Sketch of output	Voltage reading from meter
1	2	From Source only					AC setting
1	3 Between R ₁ & R ₂						AC setting
2	3 Between R ₁ & R ₂						AC setting
4	3 next to load Resistor R ₃	D ₁					AC setting
4	3 next to load Resistor R ₃	D ₁ and D ₂					AC setting
4	3 next to load Resistor R ₃	D ₁ and D ₂ and C	Has No meaning DC voltage	Has No meaning DC voltage	V _{DC}		DC setting

The AC/DC/Ground switch on the oscilloscope should be should be set to the AC position for the following measurements. This is the measurement of the Ripple Voltage

Location of Probe	Location of Ground	Component s in circuit	Vpp	Vmax Amplitude	V _{rms}	Sketch of output	Voltage reading from meter
4	3 next to load Resistor R ₃	D ₁ and D ₂ and C					AC setting